

# Installation Instructions

## SNAP 'H' HIGH TOP COLLARS

### PRODUCT:

SNAP H50 FWS-RR  
SNAP H65 FWS-RR  
SNAP H100 FWS-RR  
SNAP H150 FWS-RR

SNAP H50 S-RR  
SNAP H65 S-RR  
SNAP H100 S-RR  
SNAP H110 S  
SNAP H150 S-RR

### APPLICATION

FWS - Floor waste  
and Shower  
S - Stack only

**!** IMPORTANT The intumescent sleeve must not be altered or tampered with.

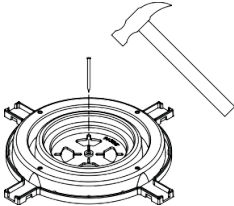
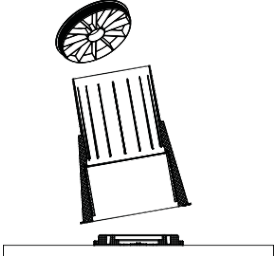
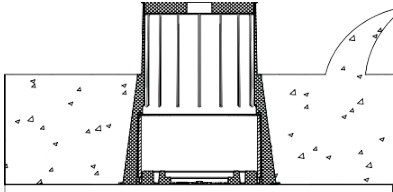
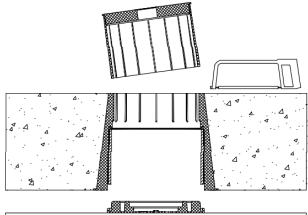
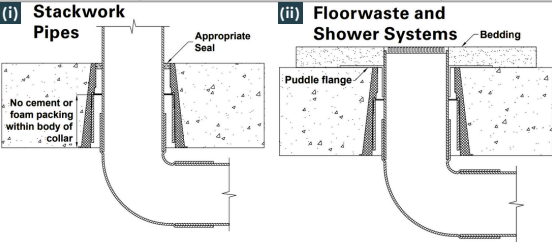
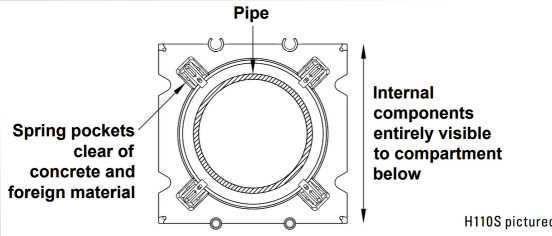
|   |  |   |
|---|--|---|
| 1 | <p>Mark the planned penetration centre point on the formwork. Use the windows (8b) of the locator plate (8) to position the central fixing hole (8a) over the centre of the mark. Secure the locator plate to the formwork using the central fixing hole.</p>  |    |
| 2 | <p>Inspect the collar to make sure it has not been damaged in transit and all components are present. Clip the collar onto the locator plate, ensuring the collar base flange (7) is flat on the formwork. Secure the collar to the formwork using preferred fixing points. Fit the cap (1) into the top of the collar. Generally, black collars are for Floorwaste and Shower applications. White collars are for Stackwork only.</p> |   |
| 3 | <p>Pour concrete. Snap cast-in Fire Collars are approved for use in concrete slabs of a range of thicknesses (see website: <a href="http://www.snapcollars.com.au">www.snapcollars.com.au</a> for tested systems).</p>   |   |
| 4 | <p>Remove the formwork. The locator plate will be pulled from the collar with the formwork, leaving a clean hole and the internal components of the collar fully exposed to the compartment underneath. If desired, cut the collar off at slab height using a saw.</p>   |    |
| 5 | <p>(i) Install the required pipe by sliding it through the collar taking care not to damage the internal collar components. Seal between the pipe and edge of penetration as follows;<br/>a. For gaps 0 - 20mm wide: Appropriate Fire-rated<br/>b. For gaps larger than 20mm wide: Non-shrink Grout<br/>(ii) Install the pipe and puddle flange as normal. Pour bedding onto the concrete.</p>   |   |
| 6 | <p>Inspect the collar to ensure no excess concrete remains around the fusible links and springs, and there is no foreign material in body of collar. Ensure that the bottom of the collar is completely exposed to the compartment.</p>  |  <p style="text-align: right;">H110S pictured</p> |

# Installation Instructions

## SNAP 'H' HIGH TOP COLLARS

### PRODUCT:

SNAP H50 FWS-RR  
SNAP H65 FWS-RR  
SNAP H100 FWS-RR  
SNAP H150 FWS-RR

SNAP H50 S-RR  
SNAP H65 S-RR  
SNAP H100 S-RR  
SNAP H110 S  
SNAP H150 S-RR

### APPLICATION

FWS - Floor waste  
and Shower  
S - Stack only

